

**How to Cite**

V, S. G., & G, V. N. (2021). Congenital adrenal hyperplasia: an old concept with new perspective. *Journal of Integral Sciences*, 4(1), 1-12. Retrieved from <https://jisciences.com/index.php/journal/article/view/35>

## Congenital adrenal hyperplasia: an old concept with a new perspective

V Siva Ganesh\*<sup>1</sup>, G Venkata Nagaraju<sup>2</sup>

<sup>1</sup>Department of Pharmacology, Sri Adichunchanagiri College of Pharmacy, Adichunchanagiri University, BG Nagar, Mandya-571448, Karnataka, India

<sup>2</sup> Department of Pharmacy Practice, School of Pharmaceutical Sciences, Jaipur National University, Jaipur, Rajasthan, India

**\*Corresponding Author**

V. Siva Ganesh

Email: ganesh.cology@gmail.com

Manuscript Submitted: 04-01-2021 Manuscript Revised: 28-01-2021 Manuscript Accepted 22-02-2021

---

**Abstract:**

Congenital adrenal hyperplasia (CAH) incorporates a social occasion of autosomal uninvolvement achieved by complete or partial distortions in one of a handful of the steroidogenic synthetic compounds related with the mix of cortisol from cholesterol in the adrenal organs. Around 1 in each 14,000 births and may cause questionable genitalia in female youngsters. By and by, CYP21A2 genotyping is seen as a significant enhancement to biochemical assessments in the finish of 21-hydroxylase need. In this study, we focus on sub-nuclear innate arrangements of 21-hydroxylase inadequacy, playing out a wide investigation of all clinical pathogenic varieties changing the whole progression of the CYP21A2 quality.

**Keywords:** CYP21A2, 21 hydroxylase, genital abnormality, Adrenal steroidogenesis, classical and Non-classical congenital adrenal hyperplasia.

**Introduction**

Congenital adrenal hyperplasia (CAH) is an autosomal latent issue that effects roughly 1 in every 14,000 births and may cause ambiguous genitalia in female neonates. CAH is brought about by transformations in the CYP21A2 quality, codes for the enzyme 21-hydroxylase [1]. 21-hydroxylase (21-OH) deficiency is an autosomal

recessive condition that accounts for around 95% of instances of inherent Adrenal Hyperplasia (IAH) [2]. The other more extraordinary types of CAH are 11 $\beta$ -hydroxylase insufficiency, 17 $\alpha$ -hydroxylase inadequacy, 3 $\beta$ -hydroxy-steroid dehydrogenase type 2 lack, P450 oxidoreductase lack, lipoid CAH and cholesterol side-chain cleavage chemical insufficiency [3]. There are numerous clinical kinds of this condition, differing from extreme or traditional to gentle late-beginning or non-old style. [4]. the degree of aldosterone deficit in classic (exemplary) CAH is characterized as salt-losing or non-salt-losing (simple virilising) [5]. Non-classical (non-exemplary) CAH is a group of diseases caused by gene mutations or problems in the steroid synthesis steps of the steroidogenic acute regulatory protein (StAR), which facilitates cholesterol transit from the mitochondrial inner membrane to the cell [6]. Adrenal steroidogenesis is a sequence of processes aided by adrenal zone-specific enzyme expression, and this process is disrupted at different points in different kinds of congenital adrenal hyperplasia. There is an additional pathway to active androgen production, in addition to the well-known steroidogenesis process, which may assume a part in the pathophysiology of inborn adrenal hyperplasia. The kind and intensity of impairment are closely related to the clinical manifestation of congenital adrenal hyperplasia [7]. In exemplary CAH, long lasting glucocorticoid and regularly likewise mineralocorticoid treatment are obligatory, though in the milder non exemplary structure, treatment is given when patients have indications like hirsutism, oligo-amenorrhoea or fruitlessness [8].

#### **CAH with Genital abnormalities:**

Youngsters with vague genitalia have different clinical introductions, etiologies, and results, going from harmless to dangerous [9] and the clinical presentation is shown in table 1.

<b>Phenotypic sex</b>	<b>CAH</b>
<b>Genotypic sex</b>	Virilized Female
<b>Prepuce</b>	46,XX
<b>Phallus</b>	Absent
<b>Labioscrotal folds</b>	Enlarged phallus/clitoris (Prader scale I-V)
<b>Gonads</b>	Symmetric, variable degree of labial fusion
<b>Urethral meatus</b>	O+O
<b>Pigmentation</b>	Separate urethral and vaginal orifice to common urogenital sinus
<b>Pubic hair</b>	Hyperpigmentation (perineum, axilla, areola)

<b>Uterus (p/r)</b>	Excessive
<b>Breast development (Tanner's stage)</b>	Present
<b>Fertility</b>	II-III

Table 1: Clinical presentation of common prototype CAH case of disorders of sexual development [10]

### **Newborn screening in India:**

Neonatal CAH is an illness which fulfills every one of the rules under infant screening (NBS) agenda proposed by Wilson and Jungner. NBS can help in early conclusion, convenient treatment and right sex task of children with traditional CAH. Male infants with old style CAH might go undetected without even a trace of genital vagueness. Foundation of explicit steroid treatment can be life-saving in infants with salt-losing CAH where adrenal emergency might be misdiagnosed as sepsis. Furthermore, NBS can perceive basic virilizing structures in male infant who might some way or another present later in youth with elements of bright adolescence. The last tallness of influenced young men might be altogether undermined at that point because of cutting edge epiphyseal development. In any case, NBS may not recognize non-traditional structures reliably when performed upon entering the world. The rate of screen positive CAH among accomplice of 104,066 children screened upon entering the world in India was 1 of every 5762 according to a new report. There were stamped territorial contrasts with most noteworthy from Chennai (1:2036) to least from Mumbai (1:9983). The frequency of salt-squandering CAH was higher (1 of every 6934) than basic virilizing type (1 out of 20,801). One more review done on a partner of 18,300 infant in Andhra Pradesh showed an occurrence of 1 of every 2600 subjects [11].

### **Role of CYP21A2 gene and 21 hydroxylase:**

The CYP21A2 quality is situated on the short arm of chromosome 6 (6p21•3) and encodes a cytochrome P450C21 catalyst. Clinical variety of CAH is principally because of changes in CYP21A2 quality which encodes the 21-Hydroxylase. In a large portion of the CAH cases, inactivating CYP21A2 changes are produced by inconsistent getting over or quality transformation occasions. The quantity of illness causing transformations in the CYP21A2 quality has nearly multiplied to 212 over the previous decade [12, 13, and 14]. Investigation of human cosmid clones has shown that there are two 21-OHase qualities in man, each found quickly to the 3' side of one of two qualities encoding the fourth part of serum supplement (C4). Apparently just the 21-

OHase quality contiguous the C4B quality encodes a functioning catalyst; homozygous erasure of this 21-OHase "B" quality causes 21-OHase lack, yet people with homozygous cancellation of the 21-OHase A quality integrate cortisol typically [15]. The mutations of CYP21A2 GENE CAUSING 21-hydroxylase deficiency shown in figure 1.

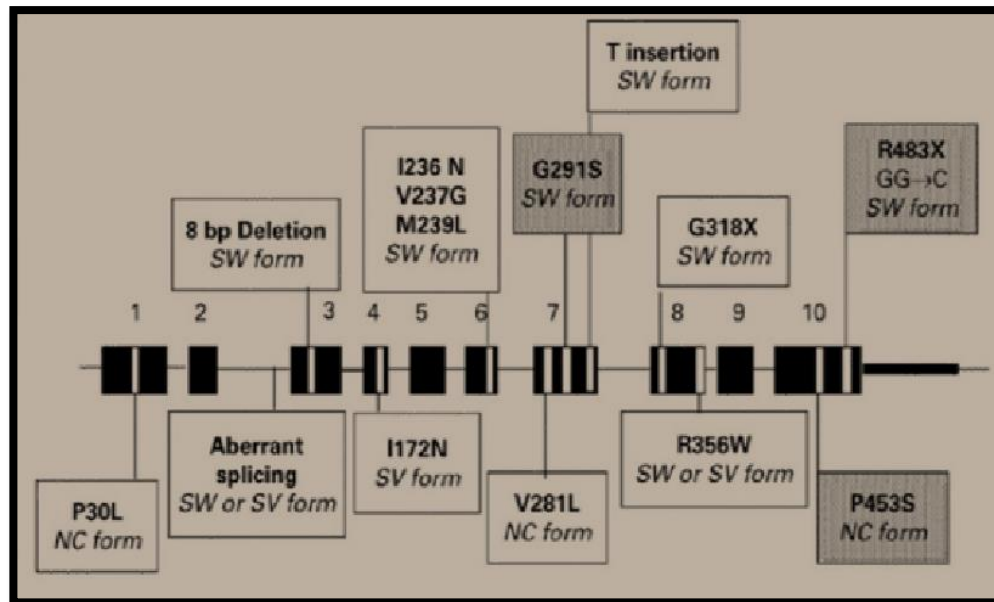

**Figure 1: Mutations in the Cyp21a2 Gene Causing 21-Hydroxylase Deficiency (Forest M G Hum. Reprod. Update 2004; 10: 469-485)**

**Classical CAH:**

Old style intrinsic adrenal hyperplasia (C-CAH) is the commonest issue/distinction of sex advancement (DSD) under the 46, XX DSD subgroup. Females with old style CAH regularly have virilised genitalia upon entering the world because of unreasonable fetal adrenal androgen creation, however are customarily raised as young ladies, essentially because of future female regenerative potential. Notwithstanding, it is hypothesized that in-utero "virilisation" of the cerebrum may likewise happen, which can influence sexual orientation job conduct (GRB) and sex character (GI) in adolescence and adulthood [16]. Youth with traditional inherent adrenal hyperplasia (CAH) show strange adrenomedullary work with diminished epinephrine levels noted in babies and newborn children. Lower epinephrine levels are related with expanded danger of disease among CAH newborn children [17]. In another review, many taking an interest ladies with old style CAH experienced shame ("aversive contrast") with regards to heartfelt and sexual circumstances, and this disgrace was related with the genital and non-genital actual elements brought about by CAH. Each of the three kinds of shame—established, expected, and disguised—that have been depicted for constant sicknesses (Earnshaw et al., 2013) were likewise promptly

distinguished in our members' reports. Heartfelt/sexual accomplices' negative remarks were inspired by both genital components like in general appearance, clitoromegaly, and clitoral erections, and non-genital substantial indications of androgen overabundance, particularly hirsutism. Both the ladies and their accomplices regularly seemed to decipher the prominent abnormal actual provisions of old style CAH essentially as atypicalities of sex, for certain accomplices unequivocally scrutinizing the ladies' actual sexual orientation and, along these lines, perhaps adding to an apparent danger to the ladies' fundamental social character [18].

### **Non-Classical CAH:**

The non-traditional type of intrinsic adrenal hyperplasia (NC-CAH) was at first called late-beginning as clinical show was seen in teenagers and grown-ups. Show of NC-CAH is inconspicuous and determination requires execution of various tests to prohibit different issues. Besides, clinical articulation of NC-CAH is variable in patients conveying a similar change. This recommends that extra factors might alter the clinical articulation of the infection including age, steroid metabolic pathways, variety in androgen creation, individual affectability to androgens, contrasts in skin affectability to androgens and perhaps the presence of different qualities adjusting 21-hydroxylase movement In patients with NC-CAH overwhelming signs are those of androgen over abundance including untimely pubarche, skin inflammation, hirsutism, polycystic ovary condition (PCOS), oligoovulation and fruitlessness [19, 20].

In contrast with the conclusion of the old style type of the sickness, which is made upon entering the world or during the neonatal period due to genital equivocality as well as salt-squandering side effects or through screening programs utilized in certain nations most instances of NCCAH are not effectively distinguishable. Also, numerous people stay asymptomatic during youth and immaturity, have typical regenerative capacity, and just become mindful of NCCAH because of the analysis of another relative and subsequent testing. Notwithstanding, most ladies with NCCAH look for clinical help when they experience manifestations of androgen abundance and, when clinical doubt prompts testing, raised basal 17 OHP levels will almost certainly highlight a determination of NCCAH. The clinical articulation of NCCAH is described by an undeniable degree of polymorphism as concerns time of beginning as well as the various signs and indications. It is accounted for that the principal clinical show of NCCAH is in 11% of cases before the age of 10 years and in 80% between the ages of 10 and 40 years. The genotype-aggregate relationship in CAH and NCCAH has not at this point been clarified. Speiser et al. recommend that most however not

the entirety of the phenotypic inconstancy in 21-hydroxylase insufficiency results from allelic variety in CYP21A2 [22].

### Adrenal Steroidogenesis:

Adrenal steroidogenesis is a powerful cycle, dependent on all over again union, with no presynthesized chemicals put away for guaranteed discharge. Cholesterol is the normal antecedent for all steroids and is effectively changed over along a progression of steps to the eventual outcome. To start steroidogenesis, cholesterol is prepared from a pool in the external mitochondrial layer (OMM), which is renewed from cytosolic capacity drops of cholesterol esters. The steroidogenic intense administrative (StAR) protein empowers cholesterol move from the OMM to the inward mitochondrial layer, where the sidechain cleavage catalyst (CYP11A1, P450scc) catalyzes the first and ratelimiting step of steroidogenesis: the change of cholesterol to pregnenolone shown in figure 2 [23].

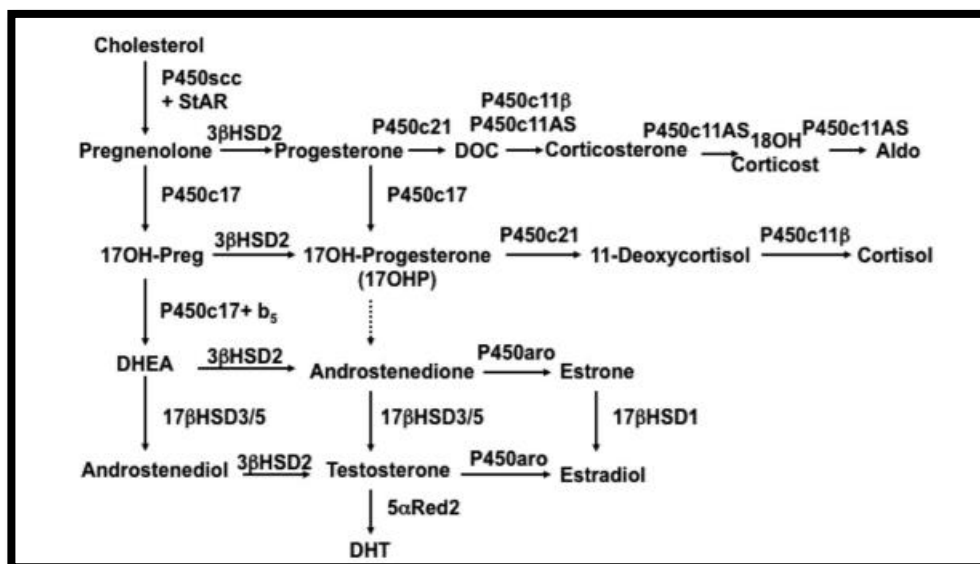

Figure 2: Significant Pathways of Steroidogenesis

Enzyme defect	Clinical features (males)	Clinical features (females)	Diagnostic hormones
21-Hydroxylase classical salt wasting	Normal genitalia Salt-wasting crisis in neonatal period Hyperpigmentation Precocious puberty	Ambiguous genitalia Salt-wasting crisis in neonatal period Hyperpigmentation	Elevated 17-OHP (>20,000 ng/dl) Increased DHEA Increased Δ4-A

	Possible infertility	Precocious puberty Possible infertility	Decreased aldosterone Decreased cortisol
21-Hydroxylase classical simple virilizing	Normal genitalia (possible phallic enlargement)	Ambiguous genitalia	Elevated 17-OHP (>10,000-20,000 ng/dl)
21-Hydroxylase non-classical	Normal genitalia at birth	Normal genitalia at birth	Elevated 17-OHP (>1,500-10,000 ng/dl), DHEA, $\Delta$ 4-A upon ACTH stimulation
3-Hydroxysteroid dehydrogenase classical and nonclassical	Ambiguous genitalia Hypospadias Salt wasting in classical form	Ambiguous genitalia If raised as female but genetic male, phallic enlargement at puberty	<u>Classical</u> Elevated 17-pregnenolone Low androstenedione. <u>Non-Classical</u> Elevated DHEA, 17-pregnenolone Low androstenedione
11 $\beta$ -Hydroxylase classical and nonclassical	Salt retention Hypertension	Ambiguous genitalia Hypertension	<u>Classical</u> Elevated DOC, 11-S, androgens <u>Non-Classical</u> Elevated 11-S $\pm$ DOC Elevated androgens
17 $\alpha$ -Hydroxylase/ 17,20-lyase	Ambiguous genitalia Hypertension Possible infertility	Delayed puberty Hypertension	Increased progesterone, DOC, DOC metabolites, B, 18-OHB Decreased cortisol Elevated ACTH Decreased DHEA Decreased Aldosterone

Table 2: Clinical and Laboratory Features of Various Disorders of Adrenal Steroidogenesis. [25]

**Treatment for congenital adrenal hyperplasia:**

The way to deal with hormonal substitution treatment in CAH isn't uniform across the globe, which might address an extra test to enhancing the executives and further developing medical services conveyance. Hydrocortisone was utilized for glucocorticoid substitution in 90–100% visits by all nations with one special case: in Brazil cortisone acetic acid derivation was utilized in 51.8% visits, hydrocortisone in 27.2%, dexamethasone in 13.2% and prednisolone/prednisone in 6.7%. Prednisone was utilized in few cases: eight visits comparing to six patients from Brazil and the United Kingdom. Dexamethasone and prednisolone were utilized in just 2% of visits in kids more youthful than 12 years, and all the more often in youngsters matured 12–18 years (dexamethasone 27.6% and prednisolone 7.8%). Hydrocortisone was most habitually directed after a three day by day portions routine. [26] In applying dexamethasone treatment to youngsters with CAH, the past and later examples of steroid power should be locked in. The mixed up presumptions that prednisone is multiple times more intense than hydrocortisone and dexamethasone is multiple times more strong than hydrocortisone in stifling adrenal androgen creation should be deserted, as prednisone and dexamethasone are 10–15 and 80–100 overlap (or more noteworthy) more powerful than hydrocortisone, in smothering adrenal androgen creation, individually. In fail to do all things considered, children will be overtreated, supporting the legend of the "improvement unsafe" glucocorticoid [27]. The diagnosis and treatment of CAH will be shown in table 3.

DISORDER	AFFECTED GENE AND CHROMOSOME	SIGNS AND SYMPTOMS	THERAPEUTIC MEASURES
21-Hydroxylase deficiency classic form	CYP21 6p21.3	Glucocorticoid deficiency	Glucocorticoid (hydrocortisone replacement)
		Mineralocorticoid deficiency	Mineralocorticoid (fludrocortisone) replacement, sodium chloride supplementation



		Ambiguous genitalia in females	Vaginoplasty and clitoral recession
		Postnatal virilization in males and females	Suppression with glucocorticoids
21-Hydroxylase deficiency non-classic form	CYP21 6p21.3	May be asymptomatic, precocious, adrenarche, hirsutism, acne, menstrual irregularity, infertility	Suppression with glucocorticoids

Table 3: Determination and Treatment of Innate Adrenal Hyperplasia

### Conclusion

CAH is a hereditary problem that might be brought about by changes in CYP21A2 quality that encodes for 21 hydroxylase. Other than the 21 hydroxylase lack, 11 $\beta$ -hydroxylase deficiency, 17 $\alpha$ -hydroxylase insufficiency, 3 $\beta$ -hydroxy-steroid dehydrogenase type 2 need, P450 oxidoreductase need, lipoid CAH and cholesterol side-chain cleavage substance inadequacy with exemplary and non-exemplary structures. Genital distortions, irregularities in the cortisol and aldosterone discharges and androgen creation and whole adrenal steroidogenesis, it is undeniably challenging to treat the condition. Because of wide scope of changes in the different qualities, the treatment is as yet testing. Since there is no remedy for this issue, substitution treatment is the best way to treat the different types of CAH with engineered glucocorticoids and mineralocorticoids till today.

### Conflict of interest

The Authors declare that they have no potential conflict of interest.

### References

1. Chawla R, Rutter M, Green J, Weidler EM. Care of the adolescent patient with congenital adrenal hyperplasia: Special considerations, shared decision making, and transition. In *Seminars in pediatric surgery.*, Vol. 28, no. 5, (2019), pp. 150-155.
2. Improda N, Barbieri F, Ciccarelli GP, Capalbo D, Salerno M. Cardiovascular health in children and adolescents with congenital adrenal hyperplasia due to

- 21-hydroxylase deficiency. *Frontiers in endocrinology.*, Vol. 11, no.10, (2019), pp. 212.
3. Claahsen-van der Grinten HL, Stikkelbroeck N, Falhammar H, Reisch N. MANAGEMENT OF ENDOCRINE DISEASE: Gonadal dysfunction in congenital adrenal hyperplasia. *European Journal of Endocrinology.*, Vol. 1, no.184(3), (2021), pp. 85-97.
  4. Concolino P, Costella A. Congenital adrenal hyperplasia (CAH) due to 21-hydroxylase deficiency: a comprehensive focus on 233 pathogenic variants of CYP21A2 gene. *Molecular diagnosis & therapy.*, Vol. 22, no.(3), (2018), pp. 261-80.
  5. Monni AF, Sobhan R, Pathan MF, Afsana F, Amin F. An 11-year-old girl with genital ambiguity: a case of non-classical congenital adrenal hyperplasia. *BIRDEM Medical Journal.* 2020 Aug 23;10(3):204-6.
  6. Kurtoğlu S, Hatipoğlu N. Non-classical congenital adrenal hyperplasia in childhood. *Journal of clinical research in pediatric endocrinology.*, Vol. 9, no.1, (2017), pp.1.
  7. El-Maouche D, Arlt W, Merke DP. Congenital adrenal hyperplasia. *The Lancet.*, Vol. 11, no.390(10108), (2017), pp. 2194-210.
  8. Hagenfeldt K, Janson PO, Holmdahl G, Falhammar H, Filipsson H, Frisé L, Thorén M, Nordenskjöld A. Fertility and pregnancy outcome in women with congenital adrenal hyperplasia due to 21-hydroxylase deficiency. *Human Reproduction.*, Vol. 23, no.7, (2008), pp. 1607-13.
  9. Lee BR, Strobel KM, Chu A. The Neonate with Ambiguous Genitalia. *NeoReviews.*, Vol. 22, no.4, (2021), pp.241-9.
  10. Khanna K, Sharma S, Gupta DK. A clinical approach to diagnosis of ambiguous genitalia. *Journal of Indian Association of Pediatric Surgeons.*, Vol. 24, no.3, (2019), pp. 162.
  11. Vats P, Dabas A, Jain V, Seth A, Yadav S, Kabra M, Gupta N, Singh P, Sharma R, Kumar R, Polipalli SK. Newborn Screening and Diagnosis of Infants with Congenital Adrenal Hyperplasia. *Indian pediatrics.*, Vol. 57, no.1, (2020), pp. 49-55.
  12. Marino S, Perez Garrido N, Ramírez P, Pujana M, Dratler G, Belgorosky A, Marino R. Molecular analysis of the CYP21A2 gene in dried blood spot samples. *MEDICINA (Buenos Aires).* 2020 Jun 1;80(3):197-202.
  13. Nageshwari R, Dhivakar M, Balakrishnan K, Selvan SA, Kumaravel V. Common CYP21A2 Gene Mutations in South Indian Congenital Adrenal

- Hyperplasia Patients. *International Journal of Human Genetics.*, Vol. 17, no.3, (2017), pp. 103-8.
14. Dayal DE, Agarwal M. A novel CYP21A2 gene mutation in classic congenital adrenal hyperplasia. *Indian Pediatr.*, Vol. 15, no.56, (2019), pp. 76.
  15. White PC, New MI, Dupont BO. Structure of human steroid 21-hydroxylase genes. *Proceedings of the National Academy of Sciences.*, Vol. 83, no.14, (1986), pp. 5111-5.
  16. Seneviratne SN, Jayarajah U, Gunawardana S, Samarasinghe M, de Silva S. Gender-role behaviour and gender identity in girls with classical congenital adrenal hyperplasia. *BMC pediatrics.*, Vol. 21, no.1, (2021), pp. 1-6.
  17. Weber J, Tanawattanacharoen VK, Seagroves A, Liang MC, Koppin CM, Ross HM, Bachega TA, Geffner ME, Serrano-Gonzalez M, Bhullar G, Kim MS. Low Adrenomedullary Function Predicts Acute Illness in Infants with Classical Congenital Adrenal Hyperplasia. *The Journal of Clinical Endocrinology & Metabolism.*, (2021).
  18. Uppugalla S, Male U, Srinivasan P. Design and synthesis of heteroatoms doped carbon/polyaniline hybrid material for high performance electrode in supercapacitor application. *Electrochimica Acta.* 2014 Nov 10;146:242-8.
  19. Male U, Uppugalla S, Srinivasan P. Effect of reduced graphene oxide–silica composite in polyaniline: electrode material for high-performance supercapacitor. *Journal of Solid State Electrochemistry.* 2015 Nov;19(11):3381-8.
  20. Uppugalla S, Srinivasan P. High-performance supercapacitor coin cell: polyaniline and nitrogen, sulfur-doped activated carbon electrodes in aqueous electrolyte. *Journal of Solid State Electrochemistry.* 2019 Jan;23(1):295-306.
  21. Uppugalla S, Srinivasan P. Polyaniline nanofibers and porous Ni [OH] 2 sheets coated carbon fabric for high performance super capacitor. *Journal of Applied Polymer Science.* 2019 Nov 5;136(41):48042.
  22. Uppugalla S, Boddula R, Srinivasan P. Methyl triphenylphosphonium permanganate as a novel oxidant for aniline to polyaniline-manganese (II, IV) oxide: material for high performance pseudocapacitor. *Journal of Solid State Electrochemistry.* 2018 Feb;22(2):407-15.
  23. Turcu AF, Auchus RJ. Adrenal steroidogenesis and congenital adrenal hyperplasia. *Endocrinology and Metabolism Clinics.*, Vol. 44, no.2, (2015), pp. 275-96.
  24. Miller WL. Mechanisms in endocrinology: rare defects in adrenal steroidogenesis. *European journal of endocrinology.*, Vol. 179, no.3, (2018), pp. 125-41.

25. New MI. Inborn errors of adrenal steroidogenesis. *Molecular and cellular endocrinology* Vol. 211, no.1-2, (2003), pp.75-84.
26. Bacila I, Freeman N, Daniel E, Sandrk M, Bryce J, Ali SR, Abali ZY, Atapattu N, Bachega TA, Balsamo A, Birkebæk N. International practice of corticosteroid replacement therapy in congenital adrenal hyperplasia: data from the I-CAH registry. *European Journal of Endocrinology.*, Vol. 184, no.4, (2021), pp. 553-63.
27. Rivkees SA. Dexamethasone therapy of congenital adrenal hyperplasia and the myth of the " growth toxic" glucocorticoid. *International journal of pediatric endocrinology.*, (2010):1-7.